

# GorillaConcreteTools

## GS-300 Early Entry

### Product Manual



# Parts Diagram

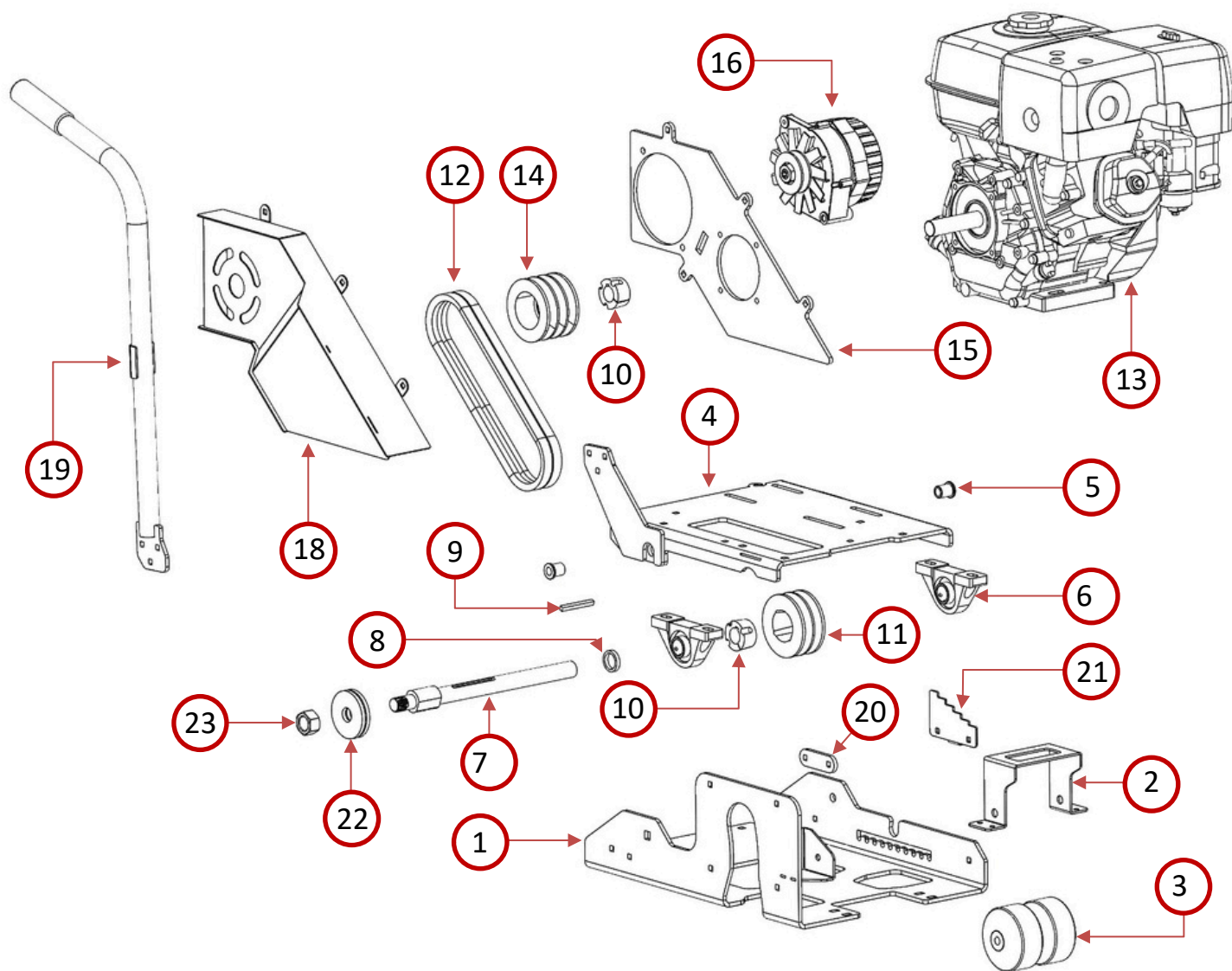

Part Number	Description
GS300 – 1	Saw Base
GS300 – 2	Front Wheel Mount
GS300 – 3	4" Wheel
GS300 – 4	Motor Plate
GS300 – 5	Motor Plate Bearing
GS300 – 6	Shaft Bearing
GS300 – 7	Blade Shaft
GS300 – 8	Blade Shaft Spacer
GS300 – 9	Blade Shaft Key
GS300 – 10	Sheave Bushing
GS300 – 11	Blade Shaft Sheave
GS300 – 12	Drive Belt

GS300 – 13	Engine
GS300 – 14	Drive Sheave
GS300 – 15	Alternator mounting Plate
GS300 – 16	Alternator
GS300 – 17	Alternator Drive Belt (Not Pictured)
GS300 – 18	Belt Guard
GS300 – 19	Lift/Lower Handle
GS300 – 20	Depth Stop Backer Plate
GS300 – 21	Depth Stop
GS300 – 22	Blade Clamp
GS300 – 23	Blade Shaft Nut
GS300 – 24	Engine Shaft Key (Not Pictured)

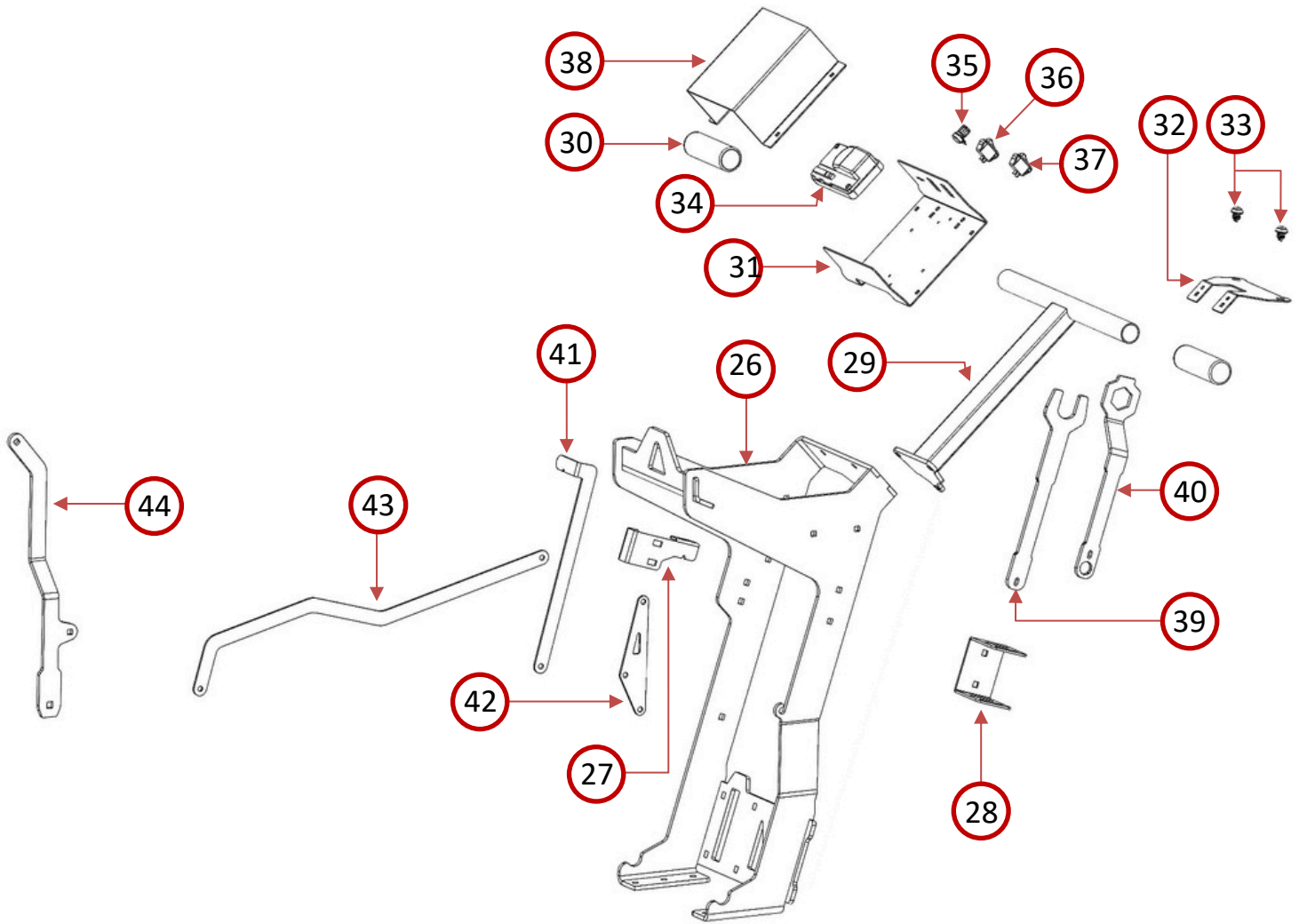

Part Number	Description
GS300 – 26	Handle Upright
GS300 – 27	Lift Handle Lock
GS300 – 28	Wrench Holder
GS300 – 29	Handle
GS300 – 30	Handle Grip
GS300 – 31	Electronics Mount
GS300 – 32	Thumb Switch Mount
GS300 – 33	Thumb Switch (sold individually)
GS300 – 34	Controller
GS300 – 35	Potentiometer
GS300 – 36	Reverse Switch

GS300 – 37	On/Off Switch
GS300 – 38	Electronics Cover
GS300 – 39	Shaft Wrench
GS300 – 40	Blade Shaft Nut Wrench
GS300 – 41	Upper Linkage Arm
GS300 – 42	Linkage Block
GS300 – 43	Lower Linkage arm
GS300 – 44	Pointer Arm

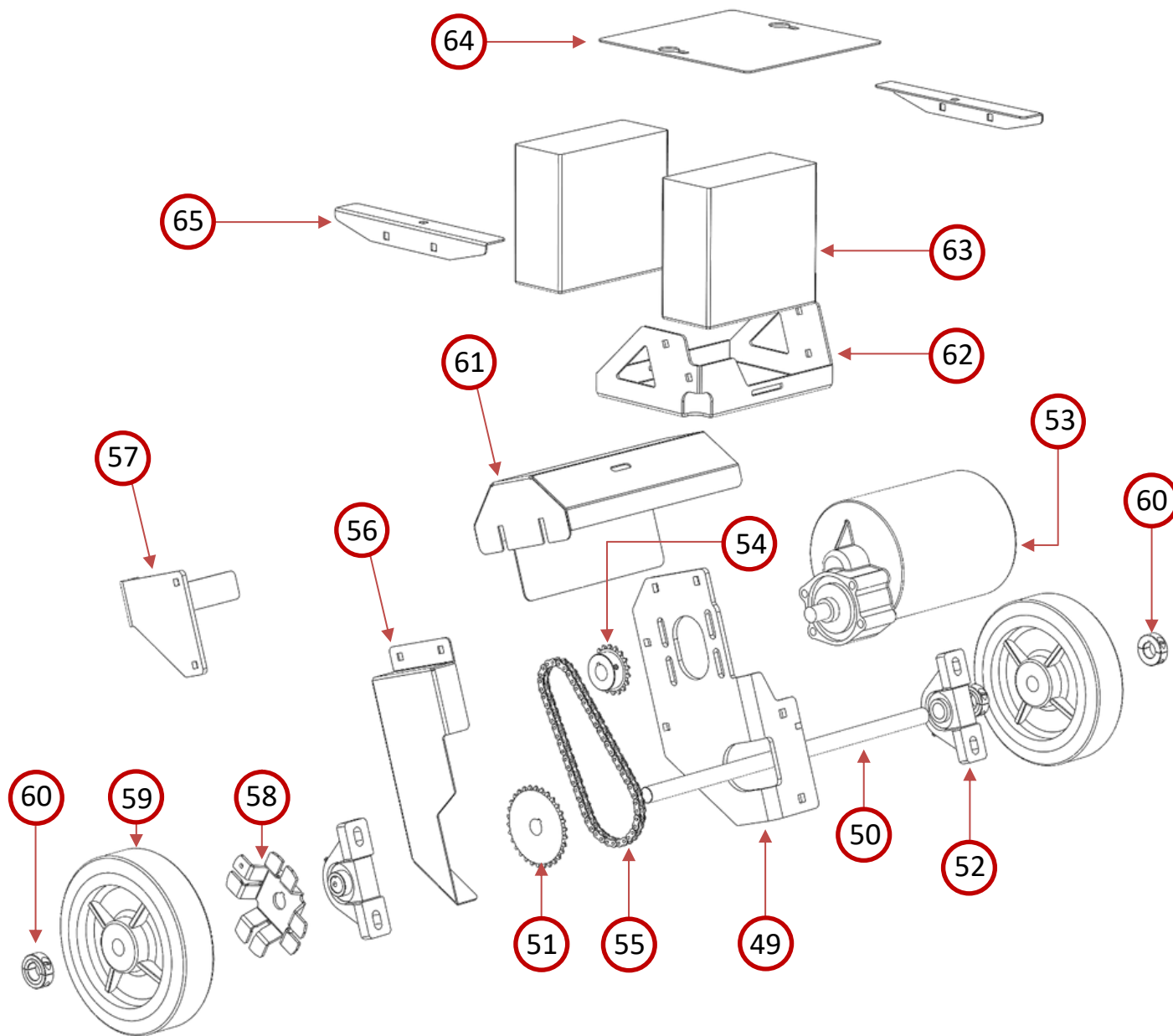

Part Number	Description
GS300 – 49	Electric Drive Motor Plate
GS300 – 50	Wheel Shaft
GS300 – 51	Wheel Shaft Sprocket
GS300 – 52	Wheel Shaft Bearing
GS300 – 53	Drive Motor
GS300 – 54	Drive Pulley
GS300 – 55	Drive Chain
GS300 – 56	Chain Cover
GS300 – 57	Foot Peg
GS300 – 58	Wheel Hub

GS300 – 59	8" Wheel
GS300 – 60	Shaft Collar
GS300 – 61	Motor Cover
GS300 – 62	Battery Tray
GS300 – 63	Battery
GS300 – 64	Battery Cover
GS300 – 65	Battery Cover Mount

# GS-300 Early Entry Dust Box

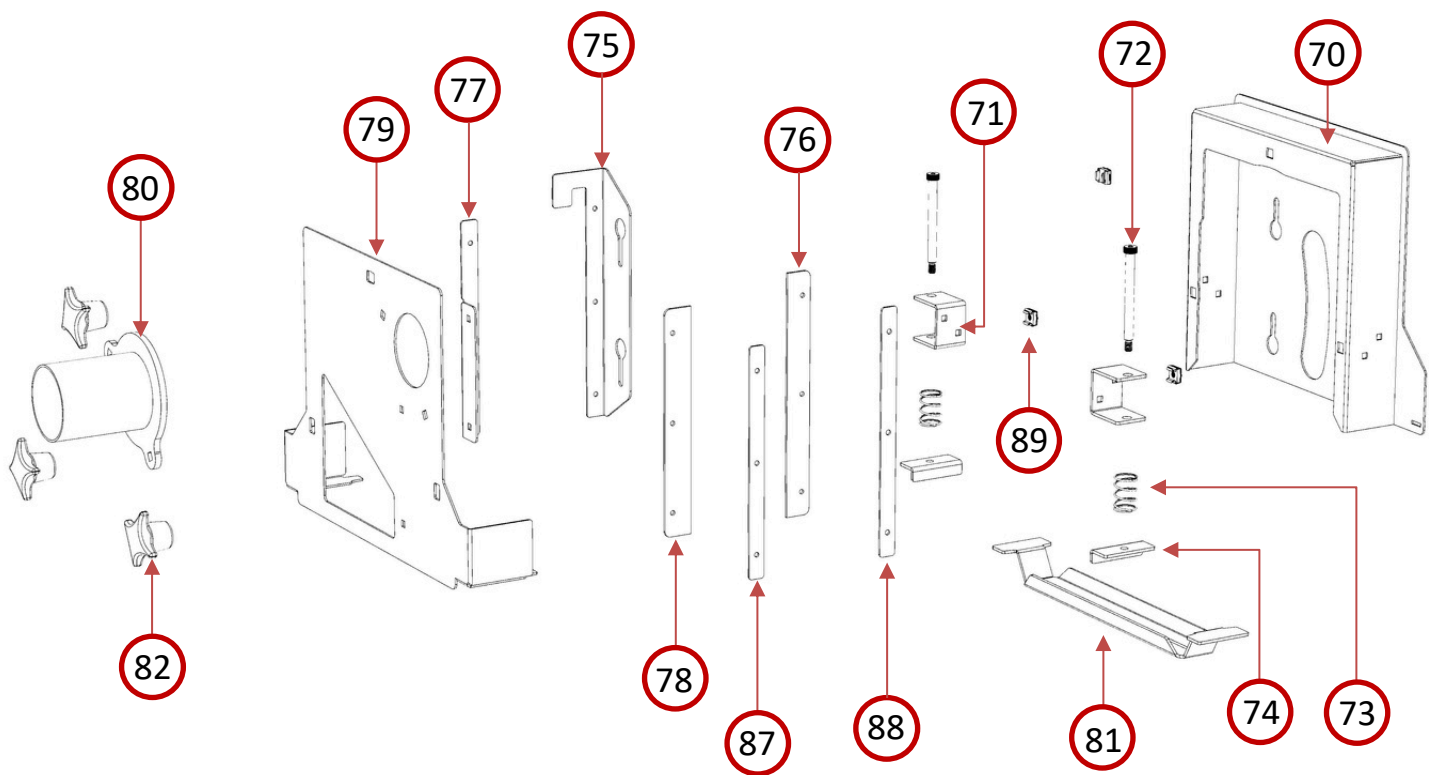

Part Number	Description
GS300 – 70.2	Dust Box
GS300 – 71	Tensioner Slide Mount
GS300 – 72	Tensioner Slide
GS300 – 73	Skid Plate Tensioning Spring
GS300 – 74	Skid Plate Tensioner
GS300 – 75	Dust Box Internal Baffle
GS300 – 76	Internal Rubber Baffle
GS300 – 77	Dust Box Door Baffle
GS300 – 78	Door Rubber Baffle
GS300 – 79.2	Dust Box Door
GS300 – 80	Dust Port
GS300 – 81	Skid Plate .090 – .125 opening
GS300 – 82	4-arm Knob
GS300 – 83	Dust Port Block Off Plate (Not Pictured)
GS300 – 84	Complete Dust Box Assembly
GS300 – 85	Skid Plate 0.25 opening (Not Pictured)
GS300 – 86	Skid plate and deflector Kit (Not Pictured)
GS300 – 87	Door Baffle Clamp
GS300 – 88	Internal Baffle Clamp
GS300 – 89	Dust Box Door Nut

