

2020

GCT-10 Parts Diagram

Gorilla Concrete Tools

An OBHC Inc. Company

33549 Royalton Road, Unit 9

Columbia Station, OH 44028

(440)236-5112

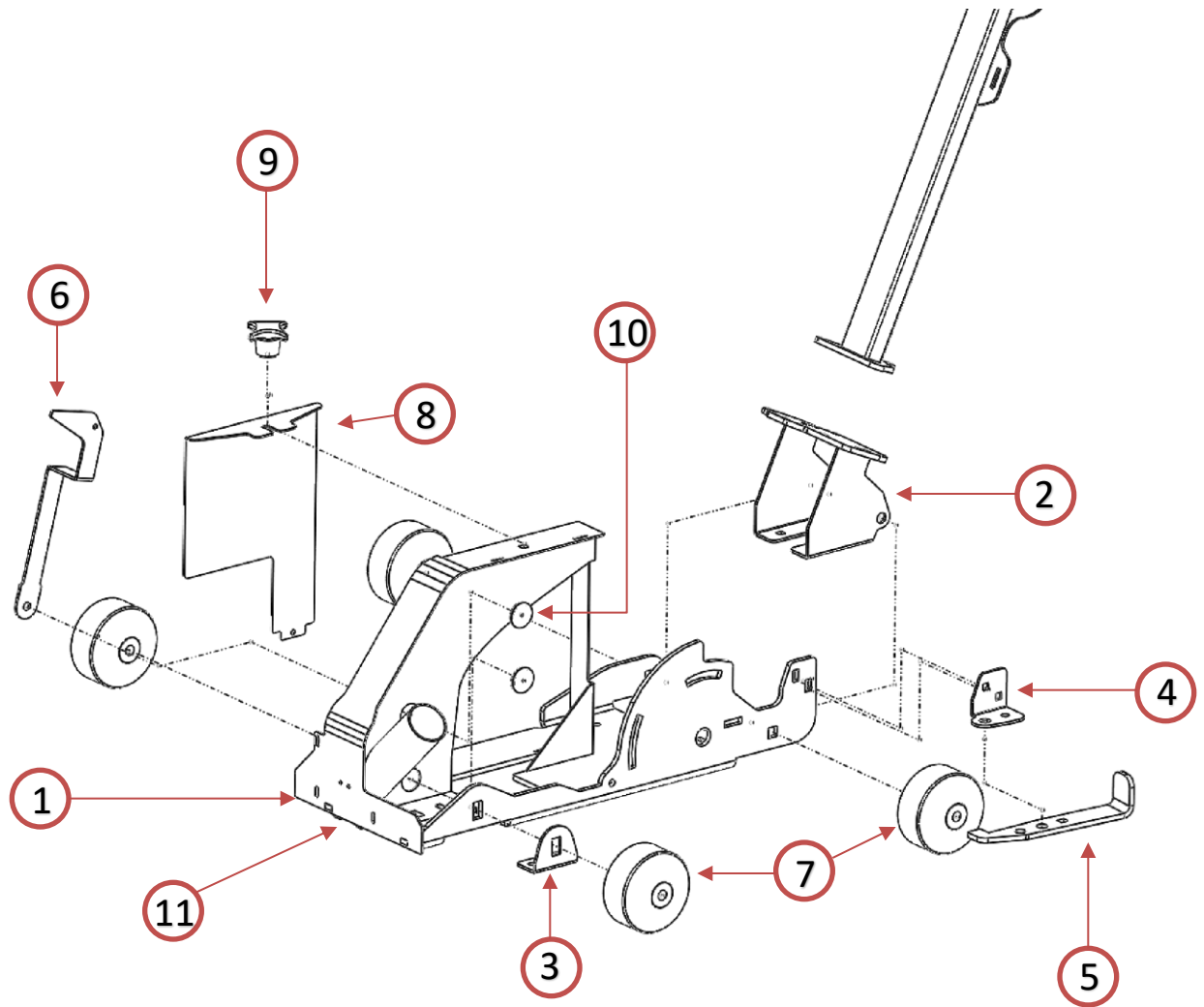

Part number	Description
10 – 1	Saw Base
10 – 2	Handle/Rear wheel mount
10 – 3	Adjustable front wheel mount
10 – 4	Motor lock mount
10 – 5	Motor lock
10 – 6	Blade pointer
10 – 7	Wheels (sold individually)
10 – 8	Blade guard
10 – 9	4-arm knob
10 – 10	Hole plug
10 – 11	Dust deflector

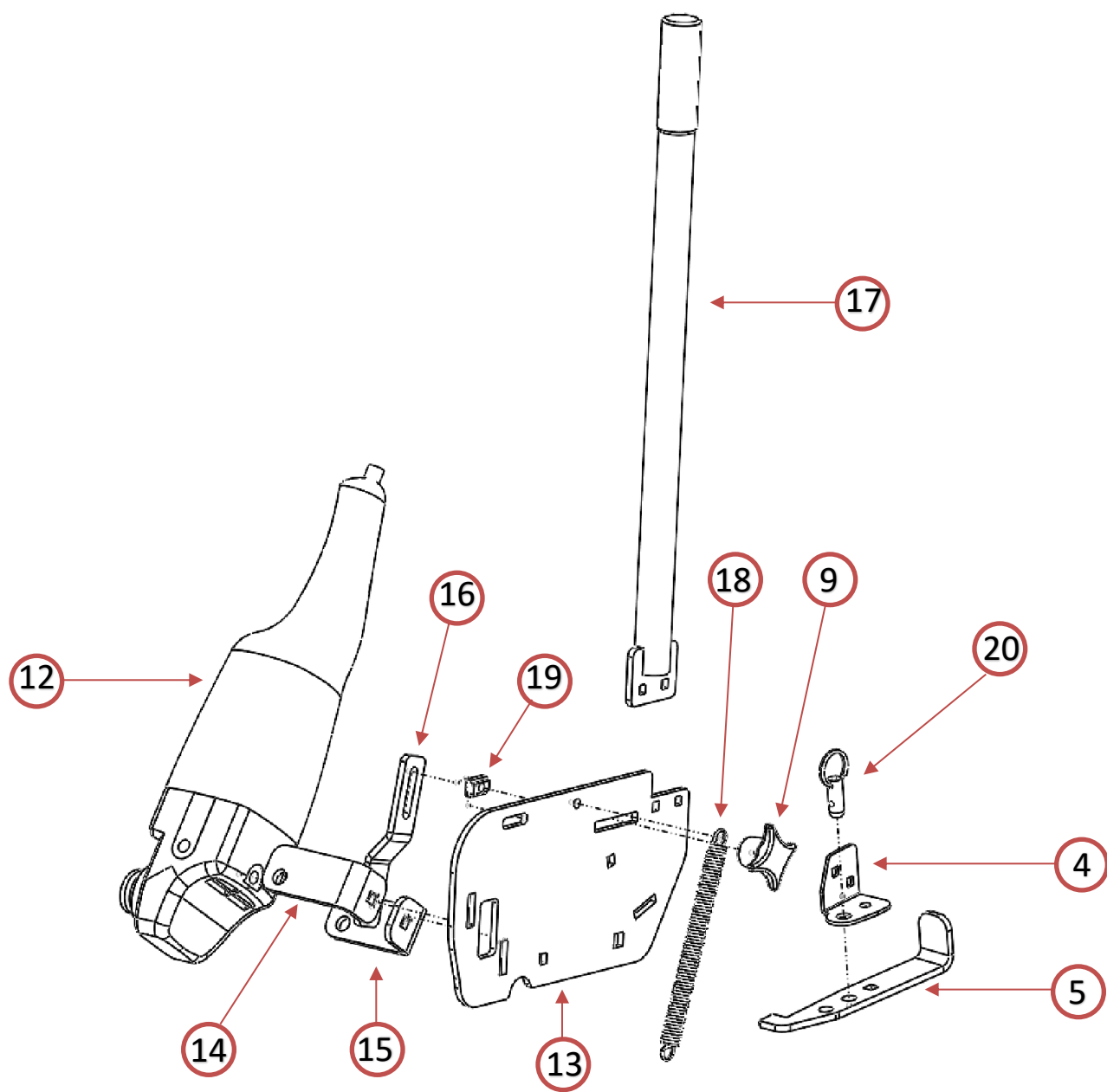

Part number	Description
10 – 12	Powerhead
10 – 13	Motor mounting plate
10 – 14	Upper motor mount
10 – 15	Lower motor mount
10 – 16	Center motor mount
10 – 17	Lift/lower Handle
10 – 18	Tension Spring
10 – 19	Depth stop
10 – 20	Detent Pin

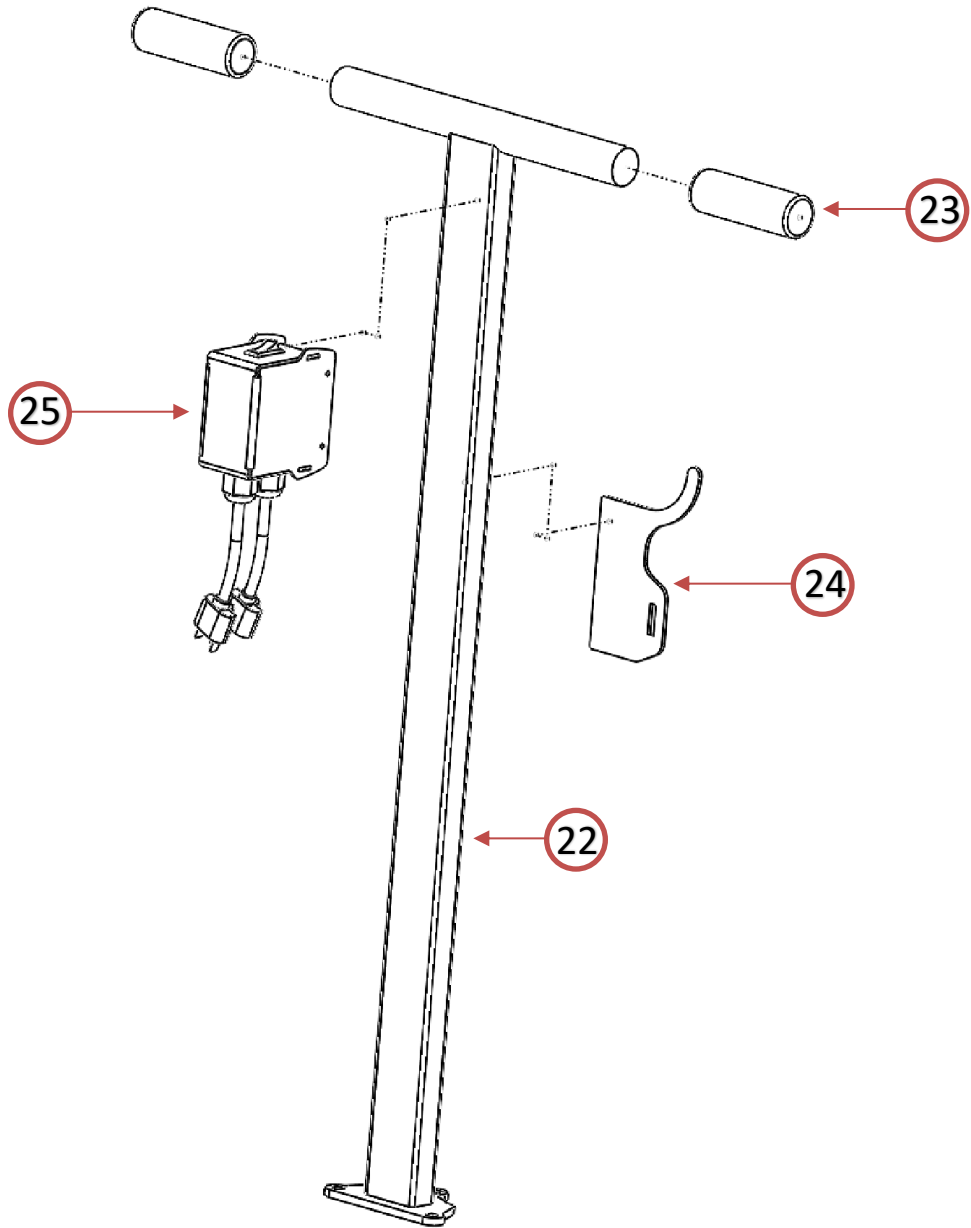

Part number	Description
10 – 21	Complete Assembly
10 – 22	Handle
10 - 23	Handle Grip
10 – 24	Cord wrap
10 – 25	Electrical box

Additional Equipment

Part number	Description
10 – 30	Maintenance kit
10 – 31	Factory Decal Set